

## EFFECT OF THE MAGNETIC FIELD ON THE MELTING TRANSITION OF Ga AND In BY nW-STABILIZED DSC

M. Minohara, K. Tozaki, H. Hayashi and H. Inaba\*

Faculty of Education, Chiba University, 1-33 Yayoi-chou, Inage-ku, Chiba, 263-8522, Japan

The melting transition of Ga and In was measured by using a nW-stabilized differential scanning calorimeter working in a magnetic bore. The magnetic effect on the thermometer was about 18 mK at 5 T, which was corrected for the measurement of the magnetic effect on the melting transition of Ga and In. The melting temperatures of Ga and In with the magnetic field of 5 T were obtained to be 8.3 and 10.2 mK, respectively higher than those without the magnetic field. These results show that the solid phase to be relatively more stable under the magnetic field. The calculated temperature shifts of the melting transition due to the magnetic field using the magneto-Clapeyron equation and the reference data of magnetic susceptibility were negative values for both Ga and In, being contradictory to the experimental results.

**Keywords:** DSC, Ga, heat flux, high resolution, In, magnetic susceptibility, melting, phase transition

### Introduction

The development of refrigerator-cooled superconducting magnet has made possible easily to obtain a strong magnetic field, for example, 10 T. It has become possible to study the magnetic effect of paramagnetic and diamagnetic substances using such a magnet [1–5]. Since the magnetic energy at 10 T is still weaker than the thermal energy  $kT$  at room temperature, it is necessary to use a highly sensitive apparatus under the strong magnetic field in order to detect the magnetic effect of diamagnetic substances.

In the previous studies [6–12], we developed a nW-stabilized differential scanning calorimeter (DSC) capable of measuring a heat as small as the order of 20 nW with a temperature resolution less than 1 mK. We measured the magnetic effect on the phase transitions of  $C_{32}H_{66}$  [9], EBBA [10], MBBA [11] and  $H_2O$  and  $D_2O$  [12] using the DSC, which was placed in a magnetic bore of a superconducting magnet. It has been shown that the transition temperatures due to phase transitions and due to melting were shifted to a higher temperature side by several or several tens of mK by applying the magnetic field of 5 T [9–12]. In the case of  $H_2O$  and  $D_2O$  [12], the temperature shifts were proportional to the square of the magnetic field. These results suggest that the temperature shifts due to the magnetic field can be discussed using the magneto-Clapeyron equation. It is noted, however, that the calculated temperature shifts using the magneto-Clapeyron equation for  $C_{32}H_{66}$ , EBBA, MBBA and  $H_2O$  and  $D_2O$  were calculated to be far smaller than the experimental values, when the

reference data of diamagnetic susceptibility were used for these materials. This problem was discussed using the term of ‘dynamic magnetic susceptibility’ in  $H_2O$  and  $D_2O$  [12].

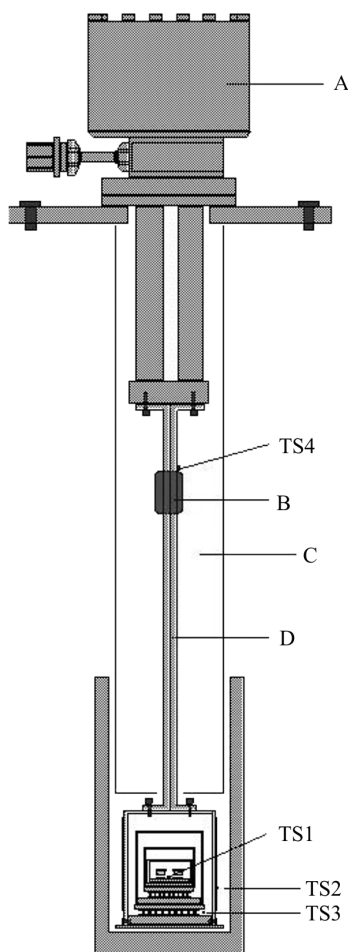
Gallium and indium are simple metals and have rather low melting temperatures, 302.93 and 429.55 K, respectively. Gallium in a solid state is diamagnetic and becomes weakly paramagnetic in a liquid state according to Panky [13] and Suzuki and Uemura [14]. Indium is diamagnetic both in the solid and liquid state according to Verhaeghe *et al.* [15] and Smithells [16]. As far as we know, the magnetic effect on the phase transitions of diamagnetic metals has not been studied. It would be very interesting to investigate how the melting transition of diamagnetic metals is affected by the application of a strong magnetic field.

In the present study, we have measured the magnetic effect on the melting transition of Ga and In using a nW-stabilized DSC and discussed it using the magneto-Clapeyron equation.

### Experimental

We have used a high resolution nW-stabilized DSC working in a magnetic bore between 120 and 420 K, which was described previously [12]. The schematic drawing of the DSC is shown in Fig. 1. The calorimeter was set in a magnetic bore and was cooled by a refrigerating head, which was connected to the calorimeter through copper plates. The temperature of the sample was measured by the Pt thermometer, TS1. The Ga

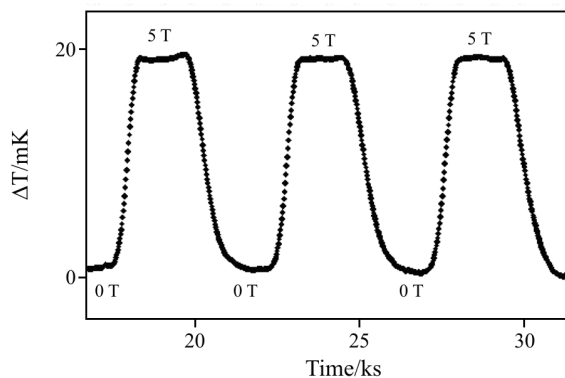
\* Author for correspondence: inabah@faculty.chiba-u.jp



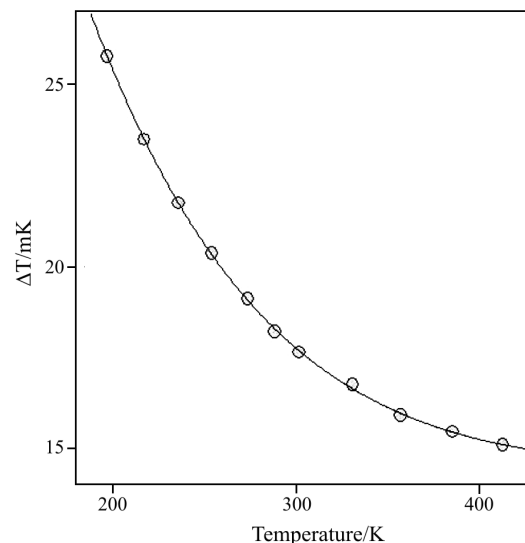
**Fig. 1** Schematic drawing of the nW-DSC working in a magnetic bore between 120 and 420 K; A – refrigerating head, B – thermal reservoir, C – thermal insulator, D – copper plates connected to the calorimeter, TS1–TS4 – Pt resistance thermometers

sample with the purity of 99.99999% and the In sample with the purity of 99.9999% were provided by the National Institute of Standard and Technology. The Ga and In sample of 2.01 and 1.97 mg, respectively, were hermetically sealed in an aluminum pan. Since Ga and In are considered to react with Al, a thin Pt sheet with the mass of 7.0 mg was laid in the Al pan both in the sample and reference sides.

Before measuring the magnetic effect on the melting transition of Ga and In sample, the magnetic effect on the Pt thermometer due to the magneto-resistance was measured. The DSC was kept at room temperature of 288.65 K without using temperature control and then the magnetic field of 5 T was applied three times to measure the magnetic effect on the Pt thermometer TS1 as shown in Fig. 2. In Fig. 2, the base temperature was corrected to be a flat line, since it drifted slowly due to the ambient temperature change. Figure 2 shows that the magnetic effect at 5 T on the Pt thermometer is reproducible and it is



**Fig. 2** The magnetic effect at 5 T at 288.65 K on the Pt resistance thermometer, TS1

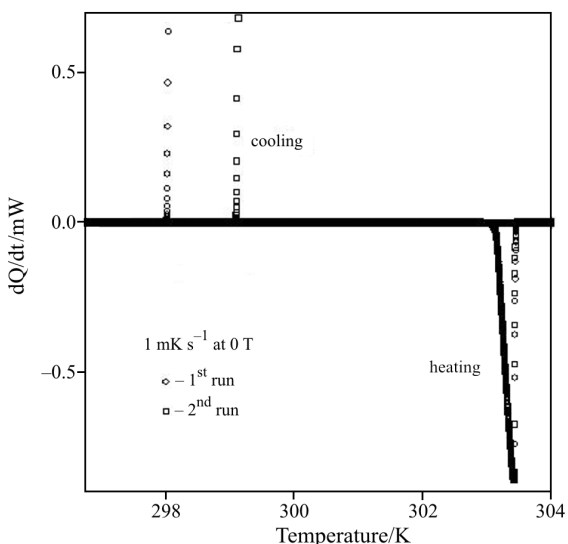


**Fig. 3** The magnetic effect at 5 T on TS1 at various temperatures

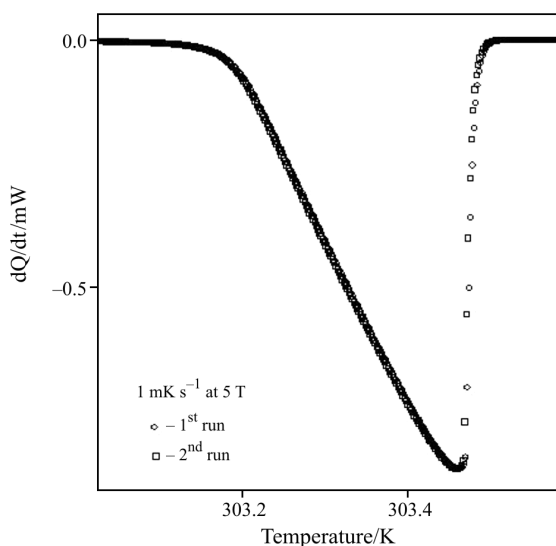
obtained to be 18.2 mK at 288.65 K. The magnetic effect on the Pt thermometer TS4 at a distant place from the maximum magnetic field of 5 T as shown in Fig. 1 was measured to be 0.4 mK, which is 2.2% of the magnetic effect on TS1. The magnetic effect on TS1 at other temperatures was measured with controlling the temperature to be constant using the thermometer TS4, similarly as shown in Fig. 2. After the small magnetic effect on TS4 was corrected, the magnetic effect at 5 T on TS1 at other temperatures was determined as shown in Fig. 3.

## Results

The heat flux measurements on the melting transition of Ga were made three times at a heating and cooling rate of  $1 \text{ mK s}^{-1}$  ( $0.06 \text{ K min}^{-1}$ ). The results of repeated two measurements are shown in Fig. 4, where almost the same results with the imprecision of  $\pm 1.3 \text{ mK}$  with respect to the melting temperature are obtained in the heating run. However, the

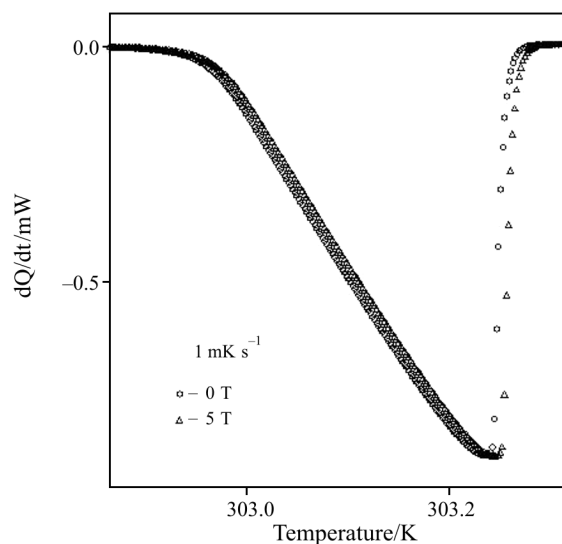


**Fig. 4** DSC curves on the melting transition of Ga without the magnetic field at a heating and cooling rate of  $1 \text{ mK s}^{-1}$ . The results of the repeated two measurements are shown



**Fig. 5** DSC curves on the melting transition of Ga with the magnetic field of 5 T at a heating rate of  $1 \text{ mK s}^{-1}$ . The results of the repeated two measurements are shown

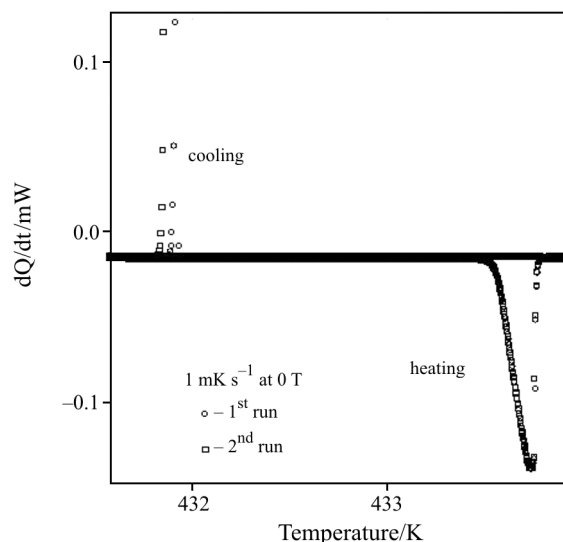
solidifying transition was not reproducible due to the large super-cooling effect in the cooling run. The large super-cooling effect of Ga in the cooling run was also observed in the measurement of magnetic susceptibility [14]. Therefore, the magnetic effect on the melting transition of Ga was measured in the heating run. The heat flux measurements on the melting transition of Ga under the magnetic field of 5 T were made three times at a heating rate of  $1 \text{ mK s}^{-1}$  and the repeated two measurements are shown in Fig. 5, where the melting temperature of Ga under the magnetic field of 5 T can also be reproducibly measured with the imprecision of  $\pm 1.1 \text{ mK}$



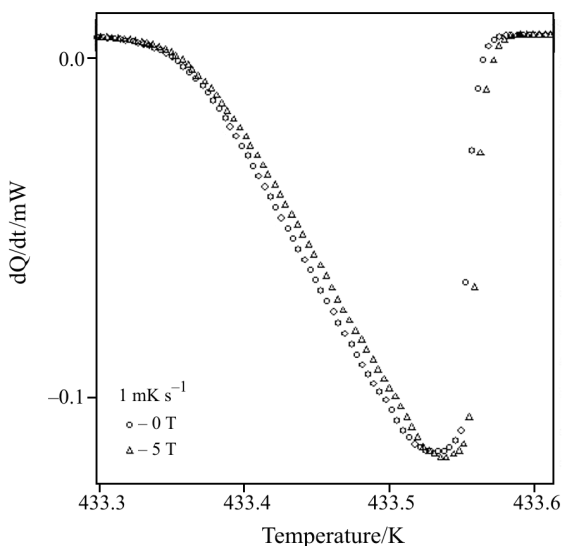
**Fig. 6** The comparison with the magnetic field of 5 T and without the magnetic field on the averaged DSC curves of the melting transition of Ga

with respect to the melting temperature. The averaged results with the magnetic field of 5 T after the correction of the magnetic effect on the Pt resistance thermometer and without the magnetic field are shown in Fig. 6 for comparison. The melting temperature with the magnetic field of 5 T is seen to be higher than that without the magnetic field. Since the shift of the transitional peak due to the magnetic field is slightly dependent on the peak position, the temperature shift was averaged over the whole range of the transitional peak. The resultant temperature shift of Ga was obtained to be  $8.3 \pm 1.7 \text{ mK}$ , where the imprecision,  $\pm 1.7 \text{ mK}$ , includes the imprecision of the repeated measurements and that of the temperature shift depending on the peak position. The higher melting temperature of Ga due to the magnetic field shows that the solid phase is stabilized by the magnetic field by some reason.

The heat flux measurements on the melting transition of In were made three times at a heating and cooling rate of  $1 \text{ mK s}^{-1}$  and the results of repeated two measurements are shown in Fig. 7, where almost the same results with the imprecision of  $\pm 0.6 \text{ mK}$  are obtained in the heating run but the solidifying temperature was not reproducible due to the large super-cooling effect in the cooling run. The heat flux measurements on the melting transition of In with the magnetic field of 5 T were also made three times at a heating rate of  $1 \text{ mK s}^{-1}$  using the DSC. The repeated measurements showed almost the same results with the imprecision of  $\pm 1.3 \text{ mK}$ . The averaged results with the magnetic field of 5 T after the correction of the magnetic effect on the Pt resistance thermometer and without the magnetic field are shown in Fig. 8 for comparison. The resultant temperature shift of In was obtained to



**Fig. 7** DSC curves on the melting transition of In without magnetic field at a heating and cooling rate of  $1 \text{ mK s}^{-1}$ . The results of the repeated two measurements are shown



**Fig. 8** The comparison with the magnetic field of 5 T and without the magnetic field on the averaged DSC curves of the melting transition of In

be  $10.2 \pm 1.5 \text{ mK}$ . The higher melting temperature of In due to the magnetic field shows that the solid phase is stabilized by the magnetic field as in the case of Ga.

## Discussion

DSC curves with and without the magnetic field for the melting transition of Ga and In show that the solid-state becomes more stable than the liquid-state by the application of the magnetic field. The relatively stable state in the low temperature phase has been found in the phase transitions in  $\text{C}_{32}\text{H}_{66}$ , MBBA and EBBA [9–11]. In these compounds, the magnetic ef-

fect was considered in relation to the orientation of linear molecules by the magnetic field, resulting from the difference in the diamagnetic susceptibility between the parallel and perpendicular direction of the molecule axis. The effects of an applied magnetic field on the phase transition of anisotropic diamagnetic substances were discussed on the basis of the magneto-Clapeyron equation [9, 10].

When we consider a diamagnetic substance at temperatures near the phase transition, which has an angle  $\theta$  with respect to the magnetic field, the molar Gibbs energy change  $dG$  including the magnetic effect is represented by the following equation [9, 10, 12]:

$$dG = -SdT - (B/\mu_0)(\chi_{\perp}\sin^2\theta + \chi_{\parallel}\cos^2\theta)dB \quad (1)$$

where  $S$  is the molar entropy,  $\chi_{\perp}$  and  $\chi_{\parallel}$  are the diamagnetic susceptibility perpendicular and parallel to the molecular axis, respectively and  $B$  is the magnetic flux. Since  $\chi_{\perp}$  and  $\chi_{\parallel}$  are both negative values, the second term of Eq. (1) becomes positive and then the system becomes unstable by the application of the magnetic field. When the phase transition is under way, the molar Gibbs energy at the high temperature phase is equal to the low temperature phase to give  $dG=0$ , then the following equation holds [9, 10, 12]:

$$-SdT = (B/\mu_0)(\chi_{\perp}\sin^2\theta + \chi_{\parallel}\cos^2\theta)dB \quad (2)$$

Since Ga and In used are the polycrystalline samples, the diamagnetic susceptibility of Ga and In can be regarded to be isotropic. Therefore,  $\chi_{\perp}$  is equal to  $\chi_{\parallel}$  ( $=\chi$ ) both for the solid and the liquid phases. Then the temperature change of the melting transition by the application of the magnetic field,  $\Delta T$ , becomes by integrating Eq. (2) as [12]:

$$\Delta T = (B^2/2\mu_0)(\chi_l - \chi_h)/(S_h - S_l) \quad (3)$$

where the subscript  $h$  and  $l$  mean the high temperature and the low temperature phase, respectively. Using the value of the diamagnetic susceptibility of Ga,  $-1.91 \cdot 10^{-5}$  for a solid and  $0.24 \cdot 10^{-6}$  for a liquid, according to Panky [13], and the entropy change of the melting of Ga obtained in this study:  $S_h - S_l = 1.44 \cdot 10^6 \text{ J K}^{-1} \text{ m}^{-3}$ ,  $\Delta T$  for the melting transition of Ga is calculated to be  $-0.13 \text{ mK}$  at 5 T. The negative value means that the melting temperature shifts to the lower temperature by the application of the magnetic field. It is brought by a relatively positive magnetic susceptibility of the liquid phase as compared with the solid phase. Similarly, using reference values [15, 16] of the diamagnetic susceptibility of solid and liquid In:  $-5.18 \cdot 10^{-5}$  and  $-4.31 \cdot 10^{-5}$ , respectively, and the entropy change of the melting of In obtained in this study:  $S_h - S_l = 4.44 \cdot 10^5 \text{ J K}^{-1} \text{ m}^{-3}$ ,  $\Delta T$  for the melting transition of In is calculated to be  $-0.19 \text{ mK}$  at 5 T.

The negative value is brought by a relatively positive magnetic susceptibility of the liquid phase as compared with the solid phase. The experimental values for the shift of the transition temperature in the melting transition at 5 T,  $\Delta T$  for Ga: 8.3 mK and for In: 10.2 mK, are both positive values.

These facts would show that the temperature shifts of the melting transition of Ga and In due to the strong magnetic field cannot be explained by the simple application to Eq. (3), if we use the reference values [13, 15, 16] for the diamagnetic susceptibility of Ga and In and use the present results of the entropy change. Since the entropy change,  $(S_{\text{h}}-S_{\text{l}})$ , is definitely positive and its magnitude is considered to be correct, the difference between the experiment and the calculation may be due to directly using the reference data of diamagnetic susceptibility. There must exist another important contribution under a strong magnetic field. The reason is not clear at the present time. More detailed interpretations are needed from the theoretical studies.

## Conclusions

The melting transitions of Ga and In were measured by using a high resolution nW-DSC working in a magnetic bore. The melting temperatures of Ga and In with the magnetic field of 5 T were obtained to be  $8.3 \pm 1.7$  and  $10.2 \pm 1.5$  mK, respectively higher than those without the magnetic field, showing the solid phase to be relatively more stable under the magnetic field. On the other hand, the calculated temperature shifts of the melting transition due to the magnetic field using the magneto-Clapeyron equation and the reference data of magnetic susceptibility were the negative values both for Ga and In. There must exist another important contribution under a strong magnetic field.

## Acknowledgements

This work has been partially supported by the Japan Society for the Promotion of Science through the Research for the Future Program and also partially supported by Grant-in-Aid for Scientific Research on priority Area 'Innovative utilization of strong magnetic fields' (Area 767; No. 15085203) from MEXT of Japan.

## References

- 1 Y. Ikezoe, N. Hirota, J. Nakagawa and K. Kitazawa, *Nature*, 393 (1998) 749.
- 2 T. Kimura, H. Ezue, H. Sata, F. Kimura, S. Tanaka and E. Ito, *Mol. Cryst. Liq. Cryst.*, 318 (1998) 141.
- 3 H. H. Shao, H. Gang and E. B. Sirota, *Phys. Rev. E.*, 57 (1998) R6265.
- 4 M. Yamaguchi, I. Yamamoto, F. Ishikawa, T. Goto and S. Miura, *J. Alloys Comp.*, 253 (1997) 191.
- 5 K. Shinohara and R. Aogaki, *Electrochemistry*, 67 (1999) 126.
- 6 S. Wang, K. Tozaki, H. Hayashi and H. Inaba, *J. Therm. Anal. Cal.*, 397 (2005) 65.
- 7 K. Tozaki, H. Inaba, H. Hayashi, C. Quan, N. Nemoto and T. Kimura, *Thermochim. Acta*, 397 (2003) 155.
- 8 S. Wang, K. Tozaki, H. Hayashi, S. Hosaka and H. Inaba, *Thermochim. Acta*, 408 (2003) 31.
- 9 H. Inaba, K. Tozaki, H. Hayashi, C. Quan, N. Nemoto and T. Kimura, *Physica B*, 63 (2002) 324.
- 10 S. Hosaka, K. Tozaki, H. Hayashi and H. Inaba, *Physica B*, 337 (2003) 138.
- 11 H. Inaba, S. Hosaka, K. Tozaki and H. Hayashi, *Physica B*, to be published.
- 12 H. Inaba, T. Saitou, K. Tozaki and H. Hayashi, *J. Appl. Phys.*, 39 (3004) 6127.
- 13 T. Pankey, *J. Appl. Phys.*, 31 (1960) 1802.
- 14 K. Suzuki and O. Uemura, *J. Phys. Chem. Solids*, 32 (1971) 1801.
- 15 J. Verhaeghe, G. Vandermeerssche and G. Le Compte, *Phys. Rev.*, 80 (1950) 758.
- 16 C. J. Smithells, *Metals Reference Book*, Butterworth, London 1967, Vol. 3, p. 688.

---

Received: June 20, 2005

Accepted: September 5, 2006

---

DOI: 10.1007/s10973-005-7134-5